

SCHMATIC DIAGRAM

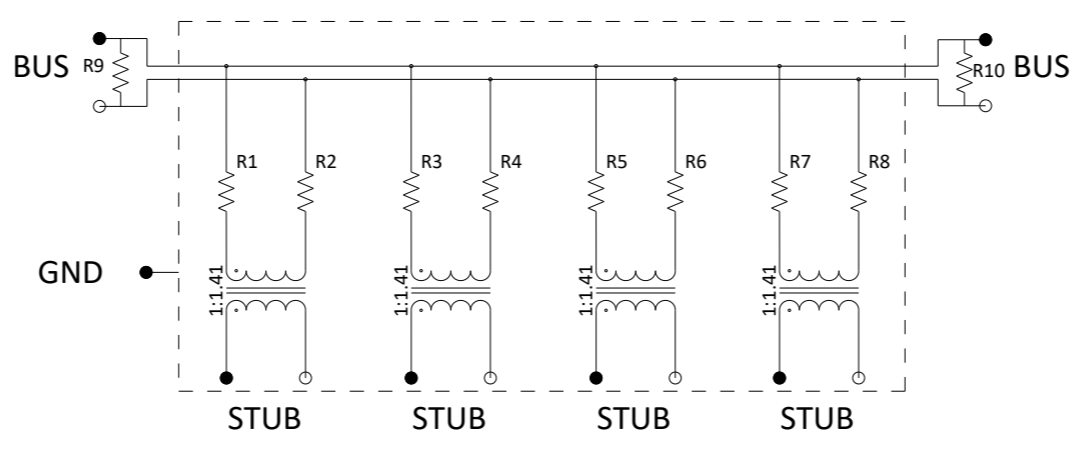

- 1.0 ELECTRICAL SPECIFICATIONS: IAW MIL-STD-1553B**
- 1.1 COMMON MODE REJECTION: -45.0 Db MAX @ 1.0MHz
  - 1.2 DROOP: 20% MAX (250kHz)
  - 1.3 OVERSHOOT & RINGING: ± 1.0V PEAK (250kHz SQUARE WAVE WITH 100Ns)
  - 1.4 STUB VOLTAGE: 1.0V TO 14.0V P-P; LINE TO LINE; SIGNAL VOLTAGE, TRANSFORMER COUPLING
  - 1.5 INPUT IMPEDANCE OF BUS: 3000 OHMS MIN. (75kHz - 1.0MHz), STUB WITH OPEN CIRCUIT
  - 1.6 CHARACTERISTIC IMPEDANCE:  $Z_0=78$  OHMS
  - 1.7 FAULT PROTECTION: 59 OHMS ± 1% 1W (R1-R8) IN SERIES WITH TRANSFORMER WINDING ON BUS SIDE
  - 1.8 TERMINATION RESISTOR VALUE: 78.7 OHMS ± 1% 2W (R9, R10) BUS TERMINATION
- 2.0 MECHANICAL SPECIFICATIONS:**
- 2.1 ENCLOSURE MATERIAL: TINPLATE 0.5mm THK.
- 3.0 ENVIRONMENTAL:**
- 3.1 OPERATING TEMPERATURE RANGE: -55°C TO 125°C
  - 3.2 VIBRATION: MIL-STD-810G\_CHG-1 METHOD 514.7 PROCEDURE I
  - 3.3 SHOCK: MIL-STD-810G\_CHG-1 METHOD 516.7 PROCEDURE V
  - 3.4 HIGH TEMPERATURE OPERATING: MIL-STD-810G\_CHG-1 METHOD 501.6 PROCEDURE II, +125°C
  - 3.5 LOW TEMPERATURE OPERATING: MIL-STD-810G\_CHG-1 METHOD 502.6 PROCEDURE II, -55°C
  - 3.6 HIGH TEMPERATURE STORAGE: MIL-STD-810G\_CHG-1 METHOD 501.6 PROCEDURE I, +125°C
  - 3.7 LOW TEMPERATURE STORAGE: MIL-STD-810G\_CHG-1 METHOD 502.6 PROCEDURE I, -55°C
  - 3.8 RAIN: MIL-STD-810G METHOD 506.5 PROCEDURE I

**! PLACING COMPONENTS UNDER THE PCB MOUNT COUPLER IS NOT RECOMMENDED.**

UNLESS OTHERWISE SPECIFIED ALL DIMENSIONS ARE IN MILLIMETERS.

PRODUCT NAME					
PCB TYPE BUS COUPLER 4 DTRM					
DOCUMENT NAME					www.delco.com.tr
DE8134 - TECHNICAL DRAWING					
SIZE	SCALE	REVISION	REVISION DATE	SHEET	
A3	2:1	1	28.11.2023	1/1	

All intellectual rights regarding this document belong to DEICO Engineering Inc.. The document is given on the conditions that it is not reproduced, used for production or other purposes and not shared with third parties without the written permission of DEICO, and receipt of the document means that these conditions are accepted and committed.